

## AMA SERIES SINGLE SECTION WALL MOUNTED CABINET

Designed to house rack mount equipment for cabling, telecommunications, IT, industrial and home installations, Stecmax AMA series is supplied flat-packed, which eases access to the installation site while reducing logistics costs and providing greater protection during transit.

- Most popular model in the market .
- Toughened glass front door.
- 1/3 assembled original volume when flat-packed.
- Reliable and rigid construction ensure over 60KG static loading capacity.

Stecmax AMA series wall mouted cabinet is of perfect structure, and extremely easy for assembling, it only takes 5 minutes for a skillful person to assemble a whole cabinet.



### ■ Features

#### A. Top Cover with Fans Optional



120mm\*120mm fans can be pre-installed on the top cover.

#### C. Fast Installation for the Door



L-shaped spring pin make it fast to install front door to the frame and easily to change door opening direction.

#### B. Removable Side Panel



Removable side panel simplifies your installation of accessories and monitoring of IT Equipment.

#### D. Easy Cable Entry



Cable entry on both of top cover and bottom panel.

## ■ Components of AMA Series Single Section Wall Mounted Cabinet

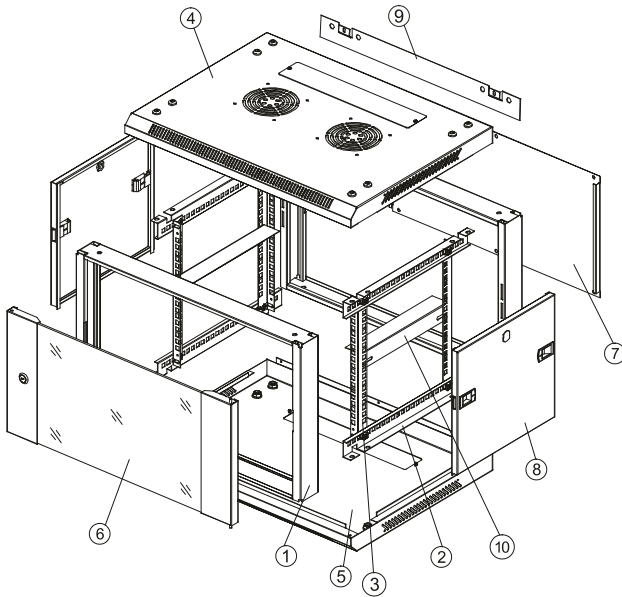

| S/N | Specification      | Quantity |
|-----|--------------------|----------|
| 1   | Frame              | 2        |
| 2   | Horizontal bracket | 4        |
| 3   | Vertical rail      | 4        |
| 4   | Top cover          | 1        |
| 5   | Bottom panel       | 1        |
| 6   | Front door         | 1        |
| 7   | Rear panel         | 1        |
| 8   | Side panel         | 2        |
| 9   | Mounting bracket   | 1        |
| 10  | L-shaped bracket   | 2        |

## ■ Optional Doors-Structure Drawing

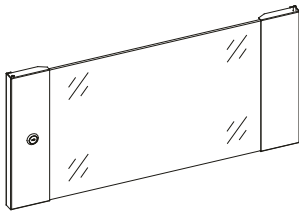

A. Tempered Glass Door  
Lock: Small Round Lock

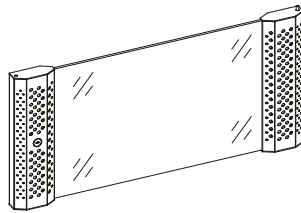

B. Tempered Glass Door, with Vented Holes  
Lock: Small Round Lock

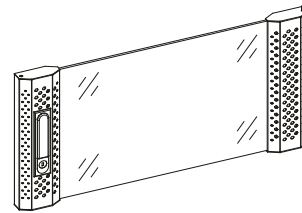

C. Tempered Glass Door, with Vented Holes  
Lock: Spring Lock

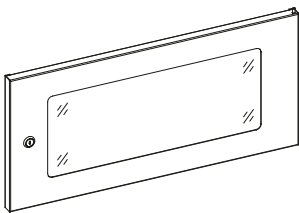

D. Tempered Glass Door  
Lock: Small Round Lock

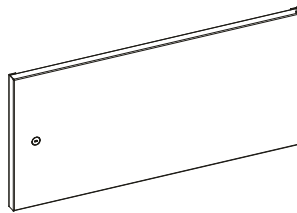

E. Solid Iron Door  
Lock: Small Round Lock

## ■ Main Dimension

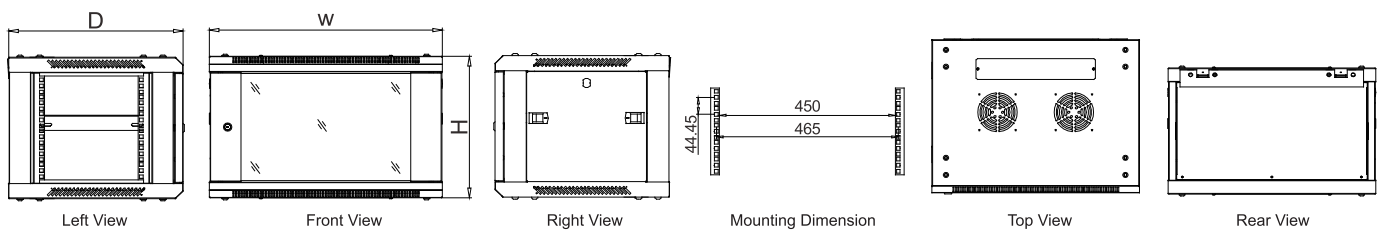

## ■ Specifications

| Model      | Capacity (U) | Dimension    | BU Packing Dimension |              | KD Packing Dimension |              |
|------------|--------------|--------------|----------------------|--------------|----------------------|--------------|
|            |              | W*D*H(mm)    | W*D*H(mm)            | Volume (CBM) | W*D*H(mm)            | Volume (CBM) |
| SX-AMA6406 | 6            | 600*450*370  | 615*460*385          | 0.109        | 615*465*250          | 0.071        |
| SX-AMA6506 | 6            | 600*500*370  | 615*510*385          | 0.121        | 615*515*250          | 0.079        |
| SX-AMA6606 | 6            | 600*600*370  | 615*610*385          | 0.144        | 615*615*250          | 0.095        |
| SX-AMA6409 | 9            | 600*450*500  | 615*460*515          | 0.146        | 615*520*250          | 0.080        |
| SX-AMA6509 | 9            | 600*500*500  | 615*510*515          | 0.162        | 615*520*250          | 0.080        |
| SX-AMA6609 | 9            | 600*600*500  | 615*610*515          | 0.193        | 615*615*250          | 0.095        |
| SX-AMA6412 | 12           | 600*450*635  | 615*460*650          | 0.184        | 650*615*170          | 0.068        |
| SX-AMA6512 | 12           | 600*500*635  | 615*510*650          | 0.204        | 650*615*170          | 0.068        |
| SX-AMA6612 | 12           | 600*600*635  | 615*610*650          | 0.244        | 650*615*250          | 0.100        |
| SX-AMA6515 | 15           | 600*500*770  | 615*510*785          | 0.246        | 785*615*170          | 0.082        |
| SX-AMA6615 | 15           | 600*600*770  | 615*610*785          | 0.294        | 785*615*250          | 0.121        |
| SX-AMA6518 | 18           | 600*500*905  | 615*510*920          | 0.289        | 920*615*170          | 0.096        |
| SX-AMA6618 | 18           | 600*600*905  | 615*610*920          | 0.345        | 920*615*250          | 0.141        |
| SX-AMA6522 | 22           | 600*500*1040 | 615*510*1055         | 0.331        | 1095*615*170         | 0.114        |

**Note:**

- 1.Package: Build-up(BU) or Knock-down (KD).
2. Hardwares: ≤12U:12 sets cage nuts  
>12U:24 sets cage nuts

**Color:**

|   |   |
|---|---|
| RAL9005   | RAL7035   |
|  |  |

**Material:**

SPCC Cold Rolled Steel.

**Optional Accessories:**

- 1.Fixed Shelf
- 2.Sliding Shelf
- 3.Cable Management
- 4.Cooling Solution
- 5.Air Flow Management
- 6.PDU

## ■ Knock-down Packaging:

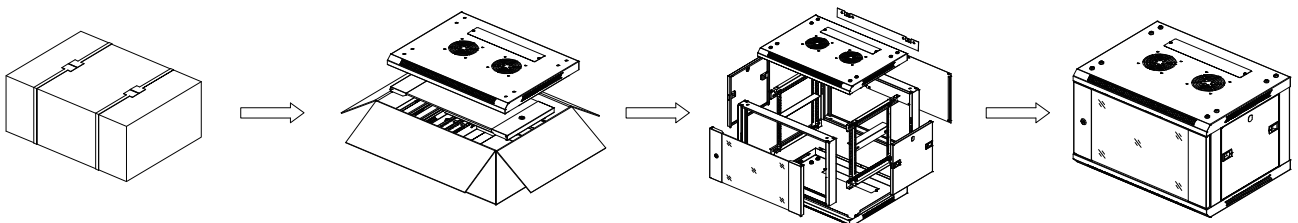

## ■ How to Define Our Model

SX-AMA6606

SX-AMA 6 6 06

